



GROB

GROB-WERKE GMBH & CO. KG

Unternehmensbereich

Burkhart Grob Flugzeugbau

8939 Mattsies

Am Flugplatz

Telefon 08268/411

Telex 539 623

MAINTENANCE MANUAL

GROB G 103

· »TWIN II«

This Maintenance Manual is for U.S. registered gliders.

Registration: Factory Serial No.: 3821..

Owner: B. Grob of America, Inc.

1070 Navajo Drive, Bluffton Airport Complex

Bluffton, OH 45817 / USA

Published September 1981

Approval of translation has been done by best knowledge and judgement - in any case the original text in German language is authoritative.

12078



Log of revisions

Revision No.	Pages affected	Description	FCAA approval signature	Date
1	1, 1a, 4, 12, 13, 21	Modified elevator (TM 315-16)		April 1982
2	1, 1a, 4, 5 6, 7, 8, 12 13, 14, 19 21, 22	Modification of serial no. 3730		June 1982

All handbooks for GROB G 103 can be ordered at:

- Burkhart Grob of America, Inc.
1070 Navajo Drive, Bluffton Airport Complex
Bluffton, OH 45817, (419)358-9015 or 9025
- Grob-Werke GmbH & Co. KG
Unternehmensbereich Burkhart Grob Flugzeugbau
Flugplatz Mindelheim-Mattsies
8939 Mattsies, West Germany
(08268) 411

16th june 1982

Pages included:

1	June 82	26	17th march 82
1a	June 82	27	17th march 82
2	Sept. 81	28	17th march 82
2a	Sept. 81	29	17th march 82
3	Sept. 81	30	17th march 82
4	June 82	31	17th march 82
5	June 82	32	17th march 82
6	June 82	33	17th march 82
7	June 82		
8	June 82		
9	Sept. 81		
10	Sept. 81		
11	Sept. 81		
12	June 82		
13	June 82		
14	June 82		
15	June 82		
16	Sept. 81		
17	Sept. 81		
18	Sept. 81		
19	Sept. 81		
20	Sept. 81		
21	June 82		
22	June 82		
23	Sept. 81		
24	Sept. 81		
25	Sept. 81		

16th june 1982

Contents	page
Log of revisions	1, 1a
Contents	2 2a
I. Technical Data	3, 4
II. Description of components	5
1 Control Linkages	5, 6
Drawing of fuselage controls	7
Drawing of rudder control	8
Drawing of wing controls	9
2 Installation of Radio	10
3 Installation of Oxygen	10
4 Instruments specifications for basic equip- ment	10
5 Pressure tubing and connections to the instruments	11
III. Rigging Data	12, 13
IV. Rigging and derigging	14
1 Rigging	14, 15, 16
2 Derigging	17
3 Transport	17
V. Maintenance	18
1 Maintenance of glider	18
2 Maintenance of brakesystem	19, 20
VI. Weight and Moments of the control surfaces	21
VII. Checks	22
1 Daily checks	22
2 Checks in specific cases	22
3 Regular service	22, 23

VIII.	Lubrications	24
IX.	General care	25
X.	Airworthiness limitations	26
	1 Annual inspection checklist	27, 28, 29, 30
	2 Inspection procedure for increase of service time	31, 32
	3 Components with a limited life time	33

(LBA approved pages: 26 through 33)

i. Technical Data

Wings

Profile Eppler

E 603

Span

b = 17,5 m 57.4 ft.

Area

F = 17,8 m² 191.8 sq. ft.

Aspect Ratio

17,1

Ailerons

Span

b_{QR} = 3,65 m 12 ft.

Chord inner

tl = 0,208 m .88 ft.

outer

to = 0,105 m .34 ft.

Area

F_{QR} = 1,14 m² 12.27 sq. ft.

% of Wing area

6,40 %

Fuselage

Length

l = 8,18 m 26,8 ft.

Width of cockpit

b = 0,71 m 28 inches

Height of cockpit

h = 1,02 m 40 inches

Height of tailplane

h = 1,55 m 5.09 ft.

Surface area ca.

F = 13 m² 139.94 sq. ft.

Fin

Height

h = 1,3 m 4,27 ft.

Area

F = 1,37 m² 14.75 sq. ft.

Aspect Ratio

1,23

Chord bottom

tu = 1,25 m 4.1 ft.

top

to = 0,86 m 2.82 ft.

Rudder

% of Fin

3,70 %

Area

F = 0,505 m² 5.44 sq. ft.

Tailplane

Span	b	= 3,3 m	10,8 ft
Area	F	= 2,18 m ²	23,5 sqft
Aspect Ratio		5,0	5,0
Chord Inner	ti	= 0,84 m	2,76 ft
Outer	to	= 0,48 m	1,57 ft

Elevator

Area	F	= 0,64 m ²	6,89 sqft
Chord inner	ti	= 0,245 m	0,80 ft

Trimm tab

Span	b	= 0,95 m	3,12 ft
Area	F	= 0,07 m ²	0,75 sqft
Chord Inner	ti	= 0,09 m	0,30 ft

Airbrakes (Grob System)

Area (Each)	F _{BK}	= 0,504 m ²	5,425 sq. ft.
Span	b	= 1,4 m	4,59 ft.
Height	h	= 0,18 m	7,1 inches

Weights

Empty weight	ca.	380 kg	838 lbs.
Load Maximum		200 kg	441 lbs.
1. Seat		110 kg	242 lbs.
2. Seat		110 kg	242 lbs.
Baggage	ca.	10 kg	22 lbs.
Load Minimum (1. Seat)		70 kg	154 lbs.
Maximum Flying Weight		580 kg	1279 lbs.
Load% of Flying Weight		36 %	
Wing Loading 25, 3-32, 6		kg/m ²	5. 18-6. 68 lbs./sq. ft.

Maximum weight of non-lifting parts 400 kg 882 lbs.

16th june 1982

II. Description of Components

II. 1 Control Linkages

The control of the TWIN II is designed as a push-rod system. The stick, bellcranks and horns are made from steel tubs or aluminium, the pushrods are made of aluminium tubing.

Elevator

The control stick force is transferred from the control stick via the stick mounting frames to the elevator pushrod. The two control sticks are firmly connected. The rear control stick is detachable and held in place by a butterfly nut. Three elevator pushrod leads from the rear stick to the elevator horn in the side fin. A connection rod with snap fastener drives the horn in the elevator. All the components of the fuselage may be dismantled. The elevator horn is laminated into the elevator. Stops for the elevator are situated on both stick mounting frames under the seats.

Aileron controls

The lateral control force is transferred from the control stick via a short connection rod to the aileron control bellcrank on the side of the fuselage. The aileron control bellcranks for both control sticks are rigidly connected by means of 2 pushrod. Pushrods lead from the rear crank via an intermediate crank at the wheel box to the lower connection to the linkage assembly in the bottom of the fuselage. The aileron control connection and the pushrods in the wing are driven via the uppercrank of the linkage assembly. The outboard aileron control differential lever in the wing drives the aileron directly via a short pushrod. All components of the aileron control system in the fuselage may be dismantled. The aileron control differential lever and the pushrod in the wing may only be dismantled through an opening made in the GFK skin. Stops for the aileron linkage are present on both control sticks.

16th June 1982

Rudder Linkages

Control cables lead from the front pedal mounting which can be adjusted in steps. The cables lie on the inside of the pedals and are routed to the bell crank of the rear pedal unit. The complete rudder linkage system may be dismantled. The stops for the rudder and the bellcrank are mounted near the rear pedal mounting.

Steuerung im Rumpf
Fuselage controls:

GROB G 103

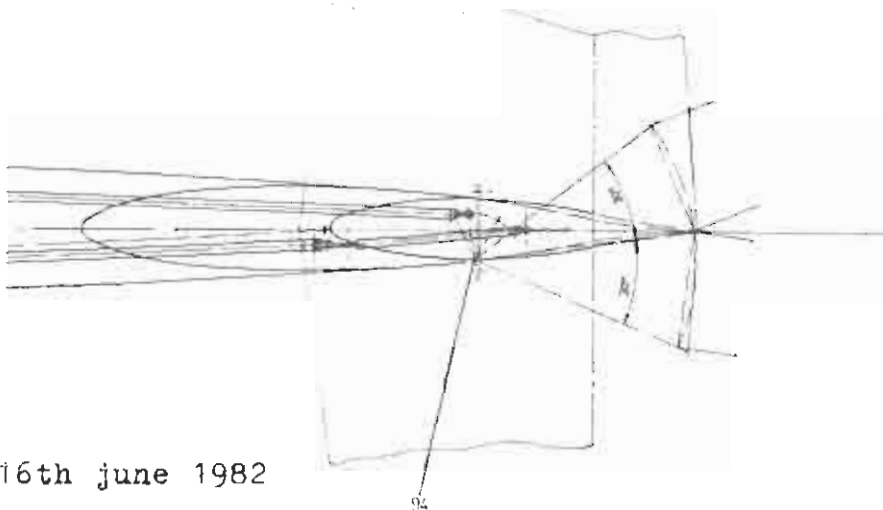
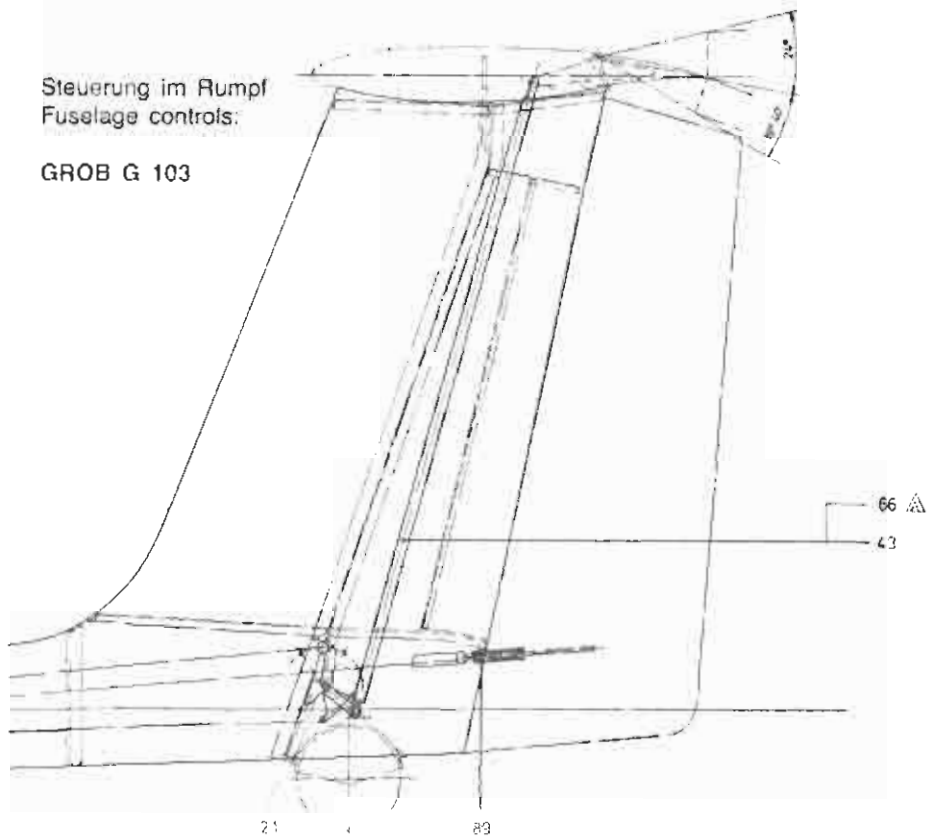

16th june 1982

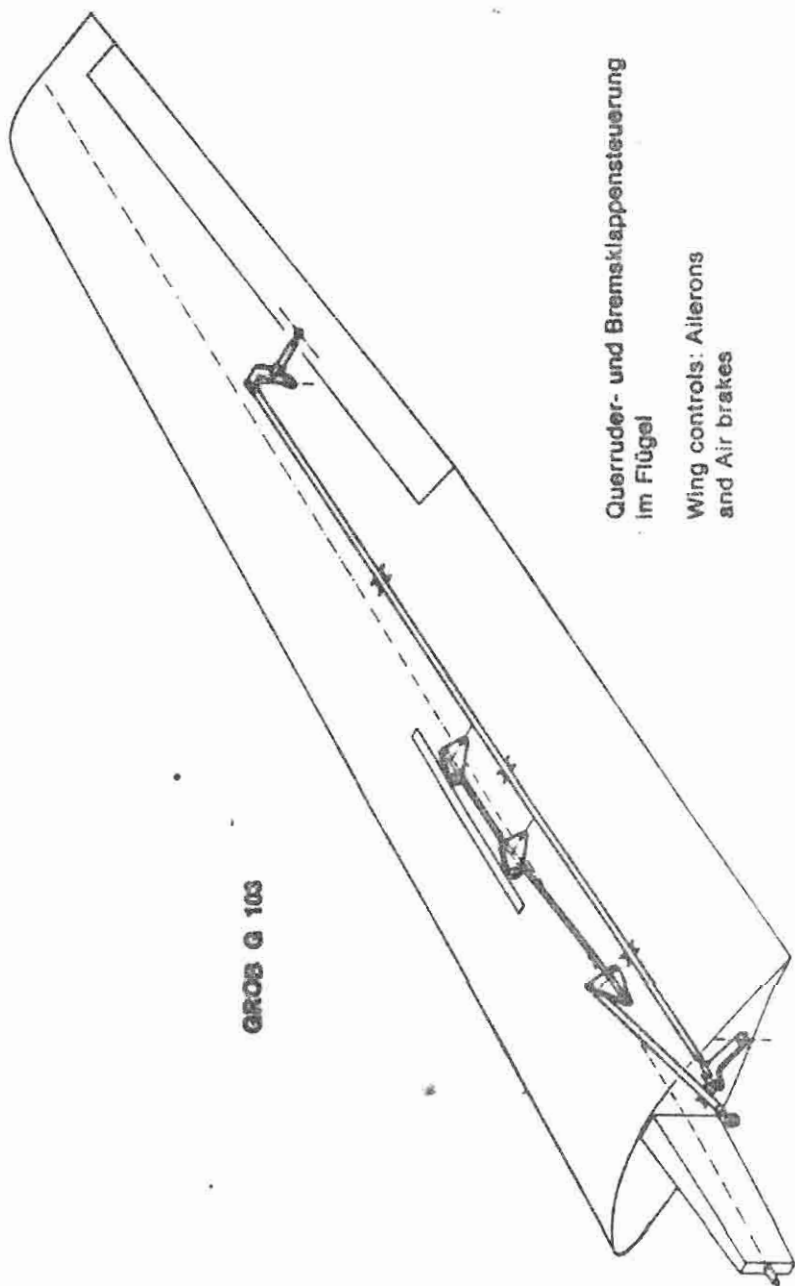

GROB G 103

Querruder- und Bremsklappensteuerung
im FlügelWing controls: Ailerons
and Air brakes

II. 2 Installation of Radio

The front instrument panel may be obtained in three layouts and can accommodate a rectangular instrument (60 x 80 mm or 148 x 47 mm) as well as 80 mm diameter instruments. The internal loudspeaker should be mounted on the rear instrument panel. "Swan neck" microphone booms may be mounted to the pilots right on the canopy frame. The shelf under the rear control linkage complex is prepared for fixing a battery. Drawings for the installation of the radio unit can be obtained on request.

II. 3 Installation of Oxygen

An Oxygen cylinder may be mounted behind the rear seat. Drawings for the installation of the Oxygen equipment can be obtained on request.

II. 4. Instruments specifications for basic equipment

Airspeed Indicator

The original certification was carried out using 2 Winter 6FMS4-2 Airspeed indicators.

A similar FAA approved airspeed indicator to meet TSO C 2 reading to 300 km/h (162 kts, 167 mph) may be used. (For example PZL PR-400 S).

Altimeter

The original certification was carried out using a Winter 4FGH 10 and a Winter 4 HM 6.

A similar FAA approved altimeter to meet TSO C 10 with a range to 35 000 feet may be used. (For example PZL W-12 S)

Magnetic Compass (compensated inside the glider)

The original certification was carried out using a Airpath C 2300.

A similar FAA approved magnetic compass to meet TSO C 7 may be used.
(For example PZL BS-1)

11.5 Pressure tubing and connections to the instruments

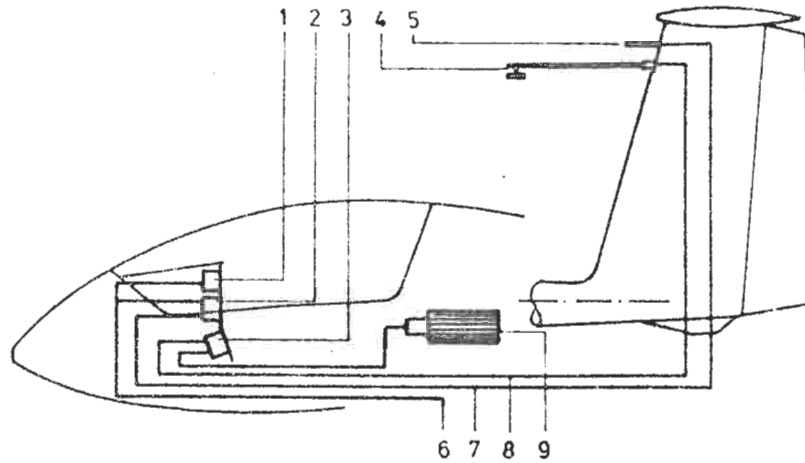

- 1 Höhenmesser (altimeter)
- 2 Fahrtmesser (air speed indicator)
- 3 Variometer (variometer)
- 4 Kompensationsdüse (total energy tube)
- 5 Staurohr (pitot tube)
- 6 Statischer Druck (static pressure) farblos (colourless)
- 7 Staudruck (pitot pressure) grün (green)
- 8 Düse (Totalenergy) rot (red)
- 9 Ausgleichsflasche (flask) blau (blue)

III. Rigging Data

Adjustment	Reference Line	Value	Tolerance
Wing — Incidence angle	Angle between the centre line of the wing and the longitudinal axis of the fuselage	2° 30'	± 15'
Wing — Sweep forward	Distance of line joining the wing tips from the reference line	0	± 40 mm (1.57 in)
Wing — Dihedral	Angle between the top surface of the wing and horizontal	3.5°	± 30'
Tailplane — Incidence angle	Angle between the chord of the tailplane and the longitudinal axis of the fuselage	0	± 15'
Reference line	Front of the wing at the root rib	QE 2980	(117.32 in.)
Control deflections	Upwards (right) Value Tolerance	Downwards (left) Value Tolerance	Measurement point from centre of rotation
Aileron Port	90 ± 10	50 ± 8	208 mm (8.19 in)
Aileron Starboard	90 ± 10	50 ± 8	
Elevator	97 ± 8	76 ± 6	245 mm (9.65 in)
Rudder	233 ± 10	233 ± 10	450 mm (17.72 in)
Release Hook	Backrelease load 0.5 to 1 kg Maximum pull to release 7 kg	70 ± 7	90 mm (3.54 in)
Trim tab (elevator neutral)		70 ± 7	90 mm (3.54 in)

16th June 1982

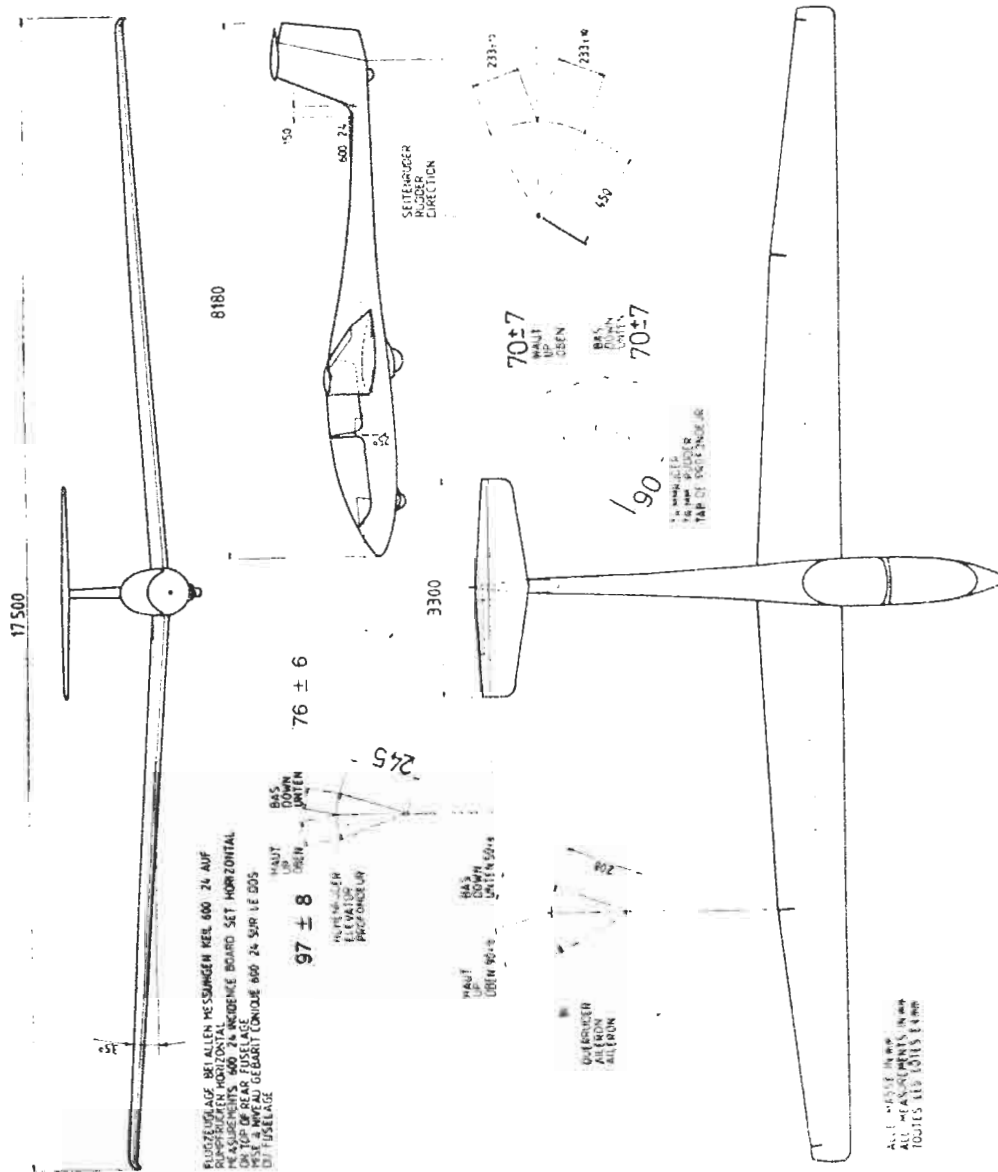

16th june 1982

IV. Rigging and derigging

IV. 1 Rigging

The fuselage must be held firmly in a horizontal position when rigging. It is recommended to use a fuselage stand or the trailer fittings are used.

The glider can be rigged by 4 people.

1. Wings

Unlock the 4 main wing fittings in the fuselage. Unlock the airbrakes on the wings. Guide the right wing into the fuselage. The safety catches on the fuselage fittings should now be released, and on gently moving the wing forward and aft it can be heard to snap into place. Next guide the left wing into the fuselage. Move the wing tips up or down so that the pin on the end of the spar stub is lined up with the appropriate hole in the opposite wing root and slide into place. Next release the safety catches on the left hand fuselage fitting and by gently moving the wing to and fro they too can be made to snap into place.

To secure the fuselage-wing linkage in the closed position the safety nut (1) must be turned into the threaded socket (2) so that the socket is pull in-boards against the red ring which is held by the guide pin (3)

16th june 1982

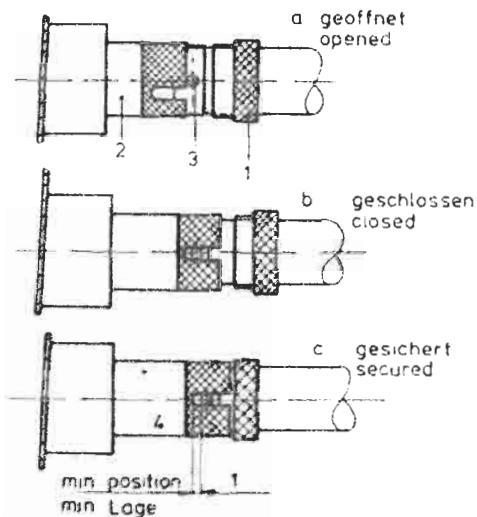

By moving the wings forward and aft strongly while turning the safety nut into the socket this linkage can be secured tight enough (4). The guide pin must not touch the end of the slot in the socket.

Check: The socket must cover the red ring.
The safety nuts must be turned hand-tight.

In the closed but unsecured position (b) the wing bolt cannot be pulled out of the fitting.

The connecting rods can be connected by means of the quick lock fasteners through the inspection opening.

Having engaged the quick locks check that the safety pin cannot be moved without pressing it down. If it cannot be slid without pressing down when the controls are properly connected.

16th june 1982

3. Tailplane

Before assembly is commenced the front cover must be opened and the rotating wing bolt pulled out to the limit. It is important to ensure, that the larger opening of the conical crillings in the inner rings of the horizontal stabilizer spar bearing fall to the rear. The tailplane can be positioned by standing behind the rudder. The tailplane can be rested on top of the fin with the elevator angled upwards so that the quick lock (System Hotellier) on the trimm tab push rod can be attached to the ball on the trimm tab horn and the quick lock (System Grob) on the elevator push rod can be attached to the bearing on the elevator horn. The front of the tailplane can then be lowered and pushed back onto the three pins. It is then necessary to tighten the wing bolt clockwise to secure the tailplane. The assembly is complete when the wing bolt is sufficiently tight that there is no play in any direction. The cover provides a safety measure as it can only be attached with the wing bolt horizontal. If necessary the wing bolt has to be turned a 1/4 turn to suit. Derigging is carried out in the opposite order and the wing bolt is turned anticlockwise and pulled fully out.

To control the correct mounting of the horizontal stabilizer it is important to ensure that the peaks of the mark-arrows at fin and elevator tabs face each other.

Checks to be made after assembly

1. Check that the 4 main wing fittings are locked.
2. Check that aileron and brake quick-actions locks are properly located on the knobs.
3. Ensure that the tow hook is functioning correctly.
4. Test the operation of the wheelbrake and the tire pressure
5. Check that the tailplane is securely seated and that the elevator push-rod is connected, control the 4 markings.
6. Rudder movement.

IV. 2. Derigging

Derigging is carried out in the opposite order and in this case it does not matter which wing is removed first. Excessive fore and aft rocking of the wing tips should be avoided.

IV. 3 Transport

We recommend the use of a closed trailer for transporting the glider. The parts must be carefully supported and secured so they cannot slide.

1. Fuselage

A fuselage trolley moulded to the shape of the fuselage and positioned in front of the main wheel. The minimum length of the trolley should be 400 mm and it can be attached to the wing fittings if required. The tail skid should be secured so that it cannot slide sideways.

2. Wings

The minimum length for the spar support should be 200 mm and should start at the face of the root rib. The mounting must be padded well with foam rubber or felt.

The mounting under the aileron inboard end should be a shaped mounting block with a minimum length of 300 mm and height of 400 mm. The mounting must be padded with felt.

3. Tailplane

Either horizontal on padded supports with the upper surface downwards and secured with straps or vertical supported on the leading edge in shaped mounting blocks.

Profile drawings are available for the manufacture of fuselage, wing and tailplane fittings.

V. Maintenance

V. 1. Maintenance of the glider

The entire surface of the glider is coated with weather resistant white polyester gelcoat.

The greatest care should be taken in maintaining the fibre glass surface of the glider. Luke warm water should be used to wash off dust, grease, dead flies and other dirty marks. More resistant dirt should be removed by using a mild cleaning agent. Only special silicon-free preparations should be used in maintaining the painted surfaces. (1 Z-Spezialreiniger - D 2, Fa. W. Sauer and Co., 5060 Bensberg or Reinigungspolish Fa. Lesonal).

Although very resistant the glider should be protected as much as possible against rain and dampness. Water that has seeped in should be dealt with by storing the glider in a dry place, frequently turning over the dismantled parts.

The most effective way to clean the canopy is to use a special perspex cleaner but if necessary luke warm water can be used. A soft, clean cloth or chamols-leather should be employed to wipe the canopy down. Never rub perspex with anything dry.

The Safety harness should be regularly checked for damage and general wear. The metal parts of the harness should be frequently checked for corrosion.

Because of its position, the winch launch hook is susceptible to getting very grimy and muddy. It must therefore be frequently inspected for damage, cleaned and greased. When the seat-well is removed the hook can easily be taken out. Remove the connecting wire from the lever and take out the retaining screws. For reconditioning, the tow hook should be sent with the record card to the tow hook manufacturer, Tost. For further details the manufacturers manuals should be consulted.

The cables and pulley for the nose and belly hooks should be checked for wear during the yearly inspection.

The main wheel tyre pressure should be kept at 2.5 to 2.8 bar nosewheel and tailwheel 2,5 bar.

V. 2. Maintenance of Brakesystem

The wheelbrake of the "TWIN " is a disk brake. When dismantling the Mainwheel for cleaning or greasing purposes, or changing the tire, unscrew Poly-stop nuts M8 and remove wheelaxle to the left. Then remove distance pipe (p 42x2) to the right. (distance bush = Distanzbüchse). Remove wheel downwards, clean all parts and grease before assemble again.

Changing of brakeshoes

- a) Remove the wheelcover.
- b) Loosen 1/4 inch screws (spanner size 11 mm) to take out brake. Do not remove brakepipe or you have to bleed again.
- c) Take off the two parts, on witch the brakelining are riveted on.
- d) Mount new brakelining with rivets, assemble in reverse order.
- e) Shape of brakelining.



66-30
M1:1

Bleeding of brakesystem

- a) Mount transparent plasticpipe on bleedingscrew put other end of pipe in a container with brakefluid.
- b) Loosen bleeding screw, when brake via lever and brakezylinder pushes brakefluid trough the brake.
- c) Bleeding is complete when no more airbubbles can be seen in transparent plastic pipe.

Remarks:

The ATE brakefluid DOT 3 (ambercoloured) is available in every shop for car parts. Standardized within Europe.

The master brake cylinder with the brake fluid reservoir is located under the baggage compartment.

The marks for the lowest and highest level of the hydraulic brake fluid have to be observed.

VI. Weights and moments of the control surfaces

Control Surface moments

The moments of the control surfaces must not exceed the following values:

Elevator (+ trim tab)	33,5 kg cm $\begin{matrix} +12\% \\ -20\% \end{matrix}$	4,5 kg $\pm 15\%$
Trim tab	1,5 kg cm $\pm 15\%$	0,52 kg $\pm 15\%$
Rudder	20,0 kg cm $\pm 10\%$	5,0 kg $\pm 10\%$
Aileron	12,0 kg cm $\pm 12\%$	6,0 kg $\pm 10\%$

The moments must be measured with the control surfaces removed. To determine the moment M the surface should be mounted at the hinge line with the minimum friction possible. The force P can be measured, for example, using a letter scale. If these values are exceeded the mass balance should be increased. Before carrying out repairs which for example involve changing the mass balance on a surface the manufacturer or his repair agent must be consulted.

(1 kg = 2,20 lbs, 1 kgcm = 7,23 ft.lbs)

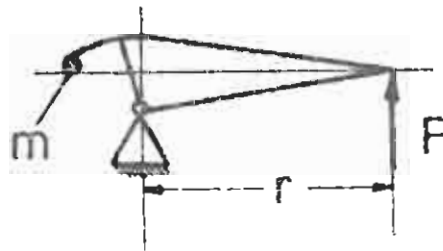

16th june 1982

VII. Checks

VII.1. Daily checks

Daily checks and checks before launch: See Flight Handbook IV-2.

VII.2. Checks in specific cases.

After a heavy landing:

Check the undercarriage mechanism under the rear seat, check the undercarriage mountings in the wheel well check the spar and root rib for white patches in the glassfibre reinforced plastics (GFK).

Check the wing fittings in the fuselage and the pins in the root rib.

Check all mounts of control surfaces.

After a Ground loop:

Check the undercarriage mounting, check the rudder controls rods and bellcranks behind the wheel well.

Check the GFK tube at the base of the fin.

Check the wing fittings in the fuselage and the connecting pins in the root rib.

Check the tail plane suspensions.

VII.3. Regular service

The following schedule of service should be carried out every 100 hours or at the annual inspection, whichever ever occurs first.

1. The entire glider should be checked for cracks, holes and bumps.
2. All fittings should be inspected for satisfactory condition (play scores and corrosion).
3. All metal parts should be examined for corrosion, cracks, deformation and if necessary reconditioned and freshly protected.
4. Check that there is no play in the wing and tailplane to fuselage fittings.
5. The control linkages (Bearings, stops, fittings, hinges and control cables) should be inspected and replaced if there is evidence of bending or corrosion.

16th june 1982

6. The controls including the brakes should be submitted to a functional test and the control deflections checked.
 7. If the controls do not move free throughout their range, search for the cause and correct.
 8. The 3 wheels and brake should be checked to be in good condition.
 9. The two hooks should be treated in accordance with their appropriate maintenance manual.
 10. Check the pitot for the ASI is clear and that the tubing to all instruments is in good condition and free of leaks or kinks.
 11. The condition and calibration of all instruments should be checked and any other equipment inspected.
 12. Equipment and instruments should be checked against the equipment list.
 13. The wing bending mode has to be established and checked with the figure stated at the approval report (Stückprüfbericht) The glider has to be supported at main-wheel and tail. The tire pressure must be 2,5-2,8 bar.
 14. After repair or change of equipment, the weight table should be updated with the new empty weight and center of Gravity by weighing or calculation.
- After extended storage check accordingly to regular service pos. 1 to 11 and inspect for evidence of rodents and birdness.

VIII. Lubrication

Ball Bearings

All bearings installed are sealed with a permanent grease filling. Greasing of bearings is therefore unnecessary.

Sliding Bearings

All slide bearings installed on the fixed control linkages do not require servicing or greasing. However, the push rod bearings in the root rib and on the tailplane mounting should be cleaned with petrol and regreased when dirty. The pins and bushes on the wing fittings should be regreased when necessary during rigging.

The pins on the tailplane fittings and the screw thread should be lubricated periodically. The hinge and catch of the cover should be occasionally oiled. Dirty release hooks are best cleaned using a brush and compressed air whilst operating the mechanism. The belly hook is accessible from inside and can be lubricated with Sprayoil or similar.

IX. General care

Dampness

As far as possible the glider should be protected from dampness. All the metal parts of the glider, with the exception of the wing and tailplane fittings are protected against damp. However, this will not prevent corrosion during extended exposure to moisture. Following any flights in rain any water which has entered the glider should be dried up and the exterior surfaces dried with a chamois leather. Polished metal parts should be regreased. Beware of condensation.

Sunlight

All structural parts of GFK glider should have white surfaces to avoid them heating up in sunlight.

Protection of the Finish

The Gelcoat surface layer is very resistant and can therefore be cleaned using a mild detergent. Ingrained dirt such as grease and dead flies, are best removed with a SILICONE-FREE polish (1 Z Spezial-Reiniger or "Reinigungspolish", Fa. Lesonal, Stuttgart). Sticky tape used for sealing the wing and tailplane joints may be removed using thinners of Petrol (Beware thinners may remove the markings).

Cleaning the Canopy

The canopy should only be cleaned using a soft clean cloth or sponge and a mild soap solution. It should be rinsed with clean water and dried with a chamois leather. "Plexipol" is a suitable polish. Never rub perspex with anything dry.

IX. General care

Dampness

As far as possible the glider should be protected from dampness. All the metal parts of the glider, with the exception of the wing and tailplane fittings are protected against damp. However, this will not prevent corrosion during extended exposure to moisture. Following any flights in rain any water which has entered the glider should be dried up and the exterior surfaces dried with a chamois leather. Polished metal parts should be regreased. Beware of condensation.

Sunlight

All structural parts of GFK glider should have white surfaces to avoid them heating up in sunlight.

Protection of the Finish

The Gelcoat surface layer is very resistant and can therefore be cleaned using a mild detergent. Ingrained dirt such as grease and dead flies, are best removed with a SILICONE-FREE polish (1 Z Spezial-Reiniger or "Reinigungspolish", Fa. Lesorial, Stuttgart). Sticky tape used for sealing the wing and tailplane joints may be removed using thinners of Petrol (Beware thinners may remove the markings).

Cleaning the Canopy

The canopy should only be cleaned using a soft clean cloth or sponge and a mild soap solution. It should be rinsed with clean water and dried with a chamois leather. "Plexipol" is a suitable polish. Never rub perspex with anything dry.

X . Airworthiness Limitations

This Airworthiness Limitations section is FAA approved for U.S. registered gliders in accordance with the provisions of 14 CFR section 21.29. In addition, this section is required by FAA Type Certificate Data Sheet No. G 39 EU and it specifies maintenance required under 14 CFR sections 43.16 and 91.163 unless an alternative program has been FAA approved.

LBA approved on : 17th march 1982

The following section specifies requirements for the instructions for continued airworthiness.

17. März 1982

 *Reinhold*
17. März 1982

XI. 1 Annual Inspection Checklist

WING

Finish

Shell

Cracks in shell

Root rib

Spar stub

Drain holes

Fittings at root rib

Aileron bearings

Aileron drive

Divebrake drive

TAILPLANE

Finish

Shell

Cracks in shell

Drain holes

Bushes for mounting

Elevator bearings

17 th march 1982



17. März 1982

FUSELAGE

Finish
Shell
Cracks in shell
Drain holes
Rudder bearings
Bushes for wing root pins
Stabilizer mounting
Cockpits
Seats
Frames
Canopies
Canopy mechanism
Canopy emergency release
Canopy window

Control stick
Elevator drive
Divebrake drive
Aileron drive
Aileron connectors
Divebrake connectors
Trim control

Pedals
Pedal adjustment
Steering cables
Earth connections
Cockpit ventilation
Backrest adjustment
Headrest adjustment

17 th march 1982



Control surfaces (Aileron, Elevator, Rudder)

Finish

Shell

Rudder ventilation

Rudder drive

Bearings

Connecting means

LANDING GEAR (Mainwheel, Tailwheel, Nosewheel)

Undercarriage and axle

Tyre

Preset load at folding strut

Bearings and joints

Drive rod

Connecting means

Locking

Overcenter

Wheel brake system

EQUIPMENT

Minimum Instrumentation

Additional Instrumentation

Operating range

Limit marks

Oxygen bottles

Working of Instrumentation

Tubing

Total energy unit

Pitot system leakfree

Static system leakfree

T. E. system leakfree

Electrical cables

Battery and fitting

Radio

Antenna

Compass deviation list

17 th march 1982

17. März 1982

- Seat belt harness
- C.G. release
- Nose release
- Weight and balance plan
- Data placard
- Cockpit placards
- Placard with serial number
- Cockpit pocket
- Baggage compartment cover

ADJUSTMENT

- Wings and horizontal tail
- Play at root ribs
- Zero setting of control surfaces
- Control surfaces deflections
- Dive brake deflection
- Wheel brake
- Trim control
- Nose release function
- C.G. release function
- Automatic C.G. release
- Aileron differentiation

Procedures and criteria for performing this inspection are contained in Section VII.3, page 22 of this manual.

XI . 2. Inspection Procedure For Increase Of Service Time

1. General

The results of fatigue tests of wingspar sections have demonstrated recently that the service time of FRP gliders may be extended to 6000 hours, if for each individual glider (in addition to the obligatory annual inspections) the air-worthiness is demonstrated according to a special multi-step inspection program particularly with regard to the service life.

2. Dates

When the glider has reached a service time of 3000 hours, an inspection must be done in accordance with the inspection program mentioned under point 3. If the results of this inspection are positive or if any defects found have been duly repaired, the service time of the glider is extended by another 1000 hours to a total of 4000 hours (first step)

The above inspection program must be repeated when the glider has reached a service time of 4000 hours. If the results of this inspection are positive or if any defects found have been duly repaired, the service time of the glider is extended to 5000 hours (second step).

When the glider has reached a service time of 5000 hours, the above inspection program again must be repeated. If the results of the inspection are still positive or if any defects found have been duly repaired, the service time may be extended to a total of 6000 hours (third step).

17 th march 1982

Heinrich
17. März 1982

For a possible service time exceeding 6000 hours procedures will be evaluated in the future.

3. In each case the latest issue of the inspection program, which will be updated according to incoming inspection results, has to be ordered from the manufacturer.
4. The inspection must only be done by the manufacturer or by a licensed repair station or inspector.
5. The results of the inspections have to be recorded in an inspection test report wherein comments are required for each inspection instruction. If the inspections are done outside the manufacturer's facilities, a copy of the records must be sent to the manufacturer for his evaluation and information.
6. The annual inspection is not affected by this inspection programm.

17 th march 1982



17. März 1982

XI.3. Components with a limited life time
a) Tow hooks

The E 75 and the G 73 Tost hooks are limited to 36 months after installation or 2000 launches which ever occurs first, at which time they are to be recertified by the manufacturer.

One is bound by the Maintenance Manuals for the nose hooks 'E 72' and 'E 75' published in May 1975 and the Maintenance Manual for the belly hooks 'Europa G 72' and 'Europa G 73' published in May 1975.

b) Oxygen Equipment

Overhaul times for specific Oxygen equipment is given in their test certificates.

Oxygen bottles must also be checked by the technical service every 5 years or according to the local lanes on use of pressurized gases.

17. März 1982



17. März 1982

INDEX

	Page
1 Foreword	1
2 Authorized Materials and Suppliers	2, 3
3 Simplified "Texture" plan	4, 5
4 Repair of GFK material	6
5 Damage to section of GFK foam-sandwich	6, 7
6 Damage to section of GFK Styropor-sandwich	8
7 Damage to section of GFK laminate	8
8 Paint-work	8
Drawings	9
9 Repair of Metal Fittings	10
10 Major Repairs	10
11 Construction details of extra equipment attachment fittings	11
12 Maintenance of Breaksystem	12, 12a

1. Foreword

The Glider "TWIN II" is constructed from Glass-Fibre reinforced Plastic (GFK). The fuselage consist of GFK laminate. The load bearing surfaces (wings) and the Tailplane consist of GFK laminate with a foam supporting layer (GFK foam-sandwich). The Tail-fin and control surfaces consists of GFK styropor sandwich.

September 1981

Styropor:

Thermopete
4 mm large
Spec. Weight 15 kg/m³

Poron-Werke GmbH
6122 Erbach
Brunnenstraße 5

Depron
3 mm large
Spec. Weight 15 kg/m³

Firma Kalle
6202 Wiesbaden/Bibrich

Filling Material for Resin

Microballoons Brown

Lackfabrik Bäder KG
7300 Eßlingen
Schließfach 25

Cotton Flock
Type FL 1 f

Schwarzwälder Textil-Werke
7623 Schenkenzell
Postfach 12

Paint

PE-Schwabbelack
White. No. 03-69120
UP-Hardener No. 07-20510
100 Schwabbelack Paint (Gel-Coat)
3 Hardener mix ratio by Weight.
Thinners No. 08-30260

Lesonal-Werke
7000 Stuttgart 30
Postfach 30 07 09

Red Paint

Nitro-Cellulose-Kombilack
Blood-Orange RAL 2002

Lackfabrik Bäder KG
7300 Eßlingen
Schließfach 25

3. Simplified "Texture" plan

Reinforced regions for special loads and stress conducting are not shown.

1. Flügel

Außenlaminat
 1 Lage 92 110 längs
 1 Lage 92 125 längs
 Kern
 Conticell 60 8 mm
 Innenlaminat
 1 Lage 92 125 diagonal

Wing

Outer laminate
 1 Layer 92 110 lengths
 1 Layer 92 125 lengths
 Core
 Conticell 60 8 mm
 Inner laminate
 1 Layer 92 125 diagonal

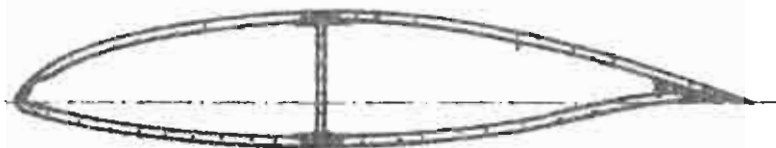
**2. Rumpf**

Von außen nach innen
 1 Lage 92 110 längs
 1 Lage 92 140 längs
 3 Lagen 92 140 diagonal

Fuselage

From outside to inside
 1 Layer 92 110 lengths
 1 Layer 92 140 lengths
 3 Layers 92 140 diagonal



3. Ruder

Höhenruder oben
 Querruder oben
 Seitenruder rechts und links

1 Lage 92 110 diagonal
 1 Lage 92 125 diagonal
 Kern Depron 3 mm
 1 Lage 92 110 diagonal

Controls

Elevator above
 Aileron above
 Rudder left and right

1 Layer 92 110 diagonal
 1 Layer 92 125 diagonal
 Core Depron 3 mm
 1 Layer 92 110 diagonal



Höhenruder unten
 Querruder unten
 2 Lagen 92 125 diagonal

Elevator below
 Aileron below
 2 Layers 92 125 diagonal

4. Höhenflosse

2 Lagen 92 110 diagonal
 Kern: Conticell 60 8 mm
 1 Lage 92 110 diagonal

Fin

2 Layers 92 110 diagonal
 Core: Conticell 60 8 mm
 1 Layer 92 110 diagonal



September 1981

After grinding out the splice, the repair must be thoroughly cleaned. Remove the dirt (also out of the foam pores) with compressed air. Wash the splice with carbon tetrachloride or Acetone, in case it has been contaminated with dirt or grease.

Fill up the pores of the foam with Resin and Microballoons until it is smooth. Then join the laminates with the correct cloth, laying it in the right direction.

Repairs must be dirt and grease free. (Figure 1)

At room temperature the resin will harden in about 8 hours.

The repair can now be ground smooth and be painted.

Warning: Grind only to the edge of the repair.

b) Damage to the whole of the Sandwich

When the inner laminate is destroyed, so there is no binding with the foam, widen the hole so far as foam material is secure, then it is possible to repair the inner laminate. A edge of at least 20 mm must be obtained (retaining laminates thickness : splice ratio approximately 1:50).

The inner laminate must be carefully ground and cleaned.

The outer laminate is repaired as described in section a). (Figure 2)

With „minor“ damage a piece of thin plywood support can be glued with Pattex from within on the inner skin, the cloth patch of the inner laminate can then be layed in and the hole filled with resin and Microballoons mixed with Styroporballs. When hardened (ca. 8 hours room temperature) the outer surface can be ground smooth and the outer cloth put on.

The plywood support should remain as part of the repair. When the hole is of large or of long size the plywood support should be held in place with thin nails which can be removed later, by pushing them out from the top surface.

Warning: The plywood support must be well jointed to avoid wrinkles in the cloth. (Figure 3)

With large holes in the sandwich, the weight of the Microballoons filler must be considered. A piece of Centicell hard foam is made before-hand, which exactly fits into the existing hole. The inside pores are closed with resin and Microballoons and laid on the inner cloth to harden, until the foam is just bendable (evtl. hot air). Then the foam with

enthickened resin (cotton flock-Microballoons) can be glued in the hole. Microballoons are used to close the outside pores, the repair is then ground and the outside cloth is then laid on.

6. Damage to section of GFK Styropor-Sandwich

Repair of Styropor damage of section.

The Styropor has a closed upper surface, the cloth is held with pure or lightly thickened resin. Splits in the upper surface pores can be filled. With large damage put a patch inside and allow to harden first before working further. This will stop the structure wrinkling.

Warning: Do not use strong heat to speed up hardening time, or Styropor will develop blisters and the repair must be done again.

7. Damage to section of GFK Laminate

Repairs to GFK laminate are simple. Splice the laminate around the hole, lay the cloth in layers on (largest patch first) and after 2-3 hours, when the resin has partially hardened smooth over with resin and Microballoons. Splice length per cloth layer ca. 20 mm. Retaining laminate thickness : Splice ratio 1:50. In case the splice is dirty it can be cleaned with Carbon Tetrochloride or Acetone.

With large damage a under laying support (plywood) should be used. Wet laminate should not bridge a gap of more than 20 mm unsupported. The plywood support can be held in place with Patitec glue and nails (e. g. metal fitting in fuselage) which can be removed afterwards. (Figure 4).

8. Paint-work

As soon as the laminate of the repaired section is hard, it can be rough ground with (80 grit) sandpaper. Large unevenness must be filled and smoothed with white polyester filler. Then with fine dry-grinding paper (150 grit) until a moderately smooth outer surface is produced. Before painting, the repaired section must be perfectly cleaned from grinding dust, separated mediums and other foreign bodies.

For successful painting, with Gel-Coat (Schwabbellack + hardener) a not too large brush should be used, putting on several thin coats, until the laminate can no longer be seen.

The first coat should be allowed to harden and then ground with

1 Lage 92 110
1 Layer 92 110

1 Lage 92 125
1 Layer 92 125



Kern
Core
Conticeil 60

Microballoons

Abb. 1
Fig. 1



Abb. 2
Fig. 2



Abb. 3
Fig. 3

Rumpfschale
Fuselage skin

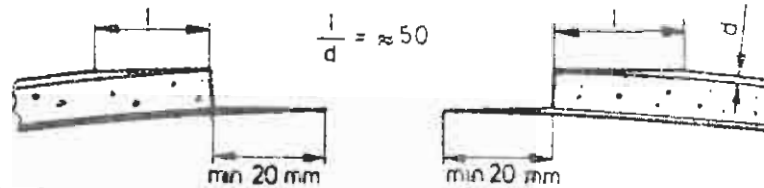
1 Lage 92 148
1 Layer 92 148

1 Lage 92 110
1 Layer 92 110

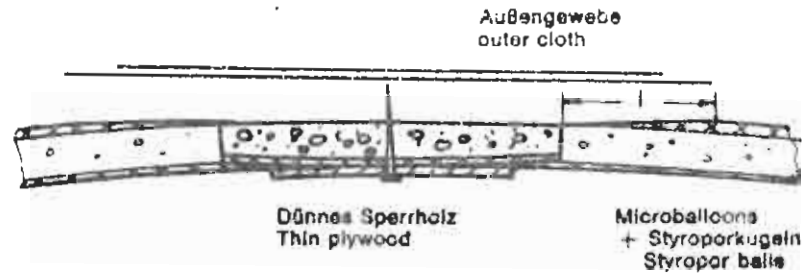
3 Lagen 92 140
3 Layers 92 140



Abb. 4
Fig. 4

Major repairs are:

- Broken off wing, fuselage, tailplane, control surface, spar stumps (spar caps)
- Ripped or torn-out - Main fittings (in fuselage \varnothing 55 x 3, Fitting of the tailplane in fin. In the wing, aileron securing both \varnothing 24 mm, joining bearing GE 25, Spar cap bolts \varnothing 25 mm).
- Destruction of main rib (vertical frame)
- Damage to the GFK laminate (tear, splits, cracks immediately near the main fittings).

11. Construction details of extra equipment attachment fittings

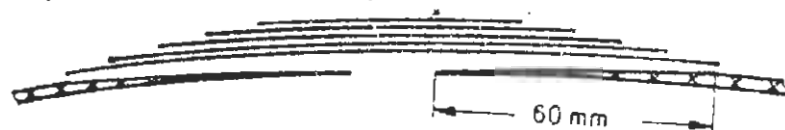
The fittings for the oxygen bottles are built in as standard on the right side of the luggage compartment. Bearing stands and quick action lock can be obtained from the manufacturer.

Other fitting points can be installed by the owner. (Figure 5)

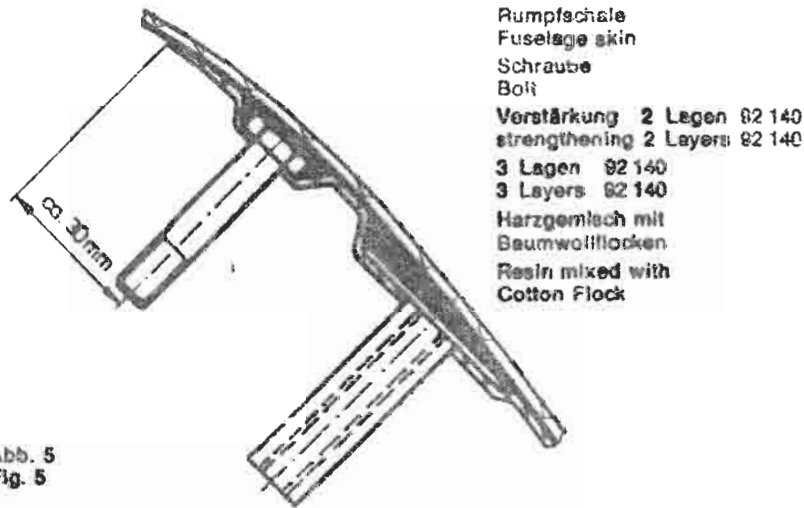

Abb. 5
Fig. 5

The fitting must be made as shown in the drawing so as to take the weight of the additional equipment. Fittings made in this manner must stand a load 10 g without failure.

When additional equipment is fitted the glider must be re-weighed to see whether the C of G is within the permitted limits.

Blueprints for the installation of radio and oxygen equipment are obtainable from the manufacturer.